

# Spring<sup>TM</sup> USA

DESIGN & BUILD



OUR SERVICES

EQUIPMENT

CUSTOM BUILDS



AGENDA

**Spring**<sup>TM</sup>  
**USA**

## OUR SERVICES

### At Spring USA, we serve **YOU.**

We work alongside you to help the worlds leading brands with their custom projects to offer solutions that increase efficiency, reliability, and the overall guest experience.

Backed by our long history working with foodservice professionals, we gaurantee the quality and durability you expect from a leader in foodservice equipment.



## OUR SERVICES

**Tell us your vision, we bring it to life.**

### CONSULTING

We partner with end users, contractors, architects, and consultants to bring years of industry experience, dedicated service, and ongoing support to projects and custom builds.

### DESIGN/ BUILD

We are capable of manufacturing products in accordance with your customers' design, power, space and budget requirements.

### POST-PRODUCTION

Our team is available for project implementation and product calibration to ensure proper set-up, as well as resources and assistance with maintenance training, warranties, and technical support.



# OUR SERVICES

## Expert team, at your service.

Our team works with you to provide professional and innovative materials that bring your plan to life.

- 1 Quotes
- 2 Renders/ drawings
- 3 CAD/ REVIT
- 4 Prototypes/ Samples

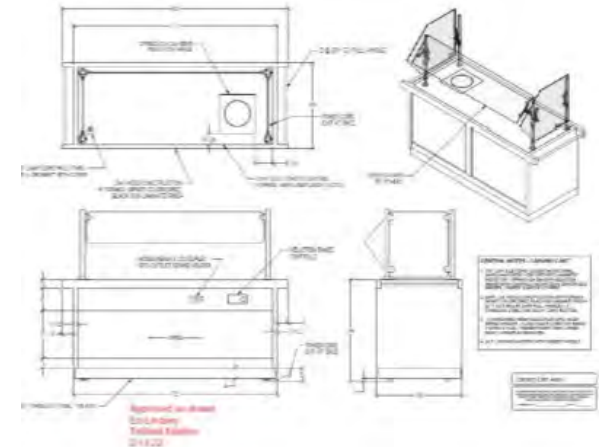
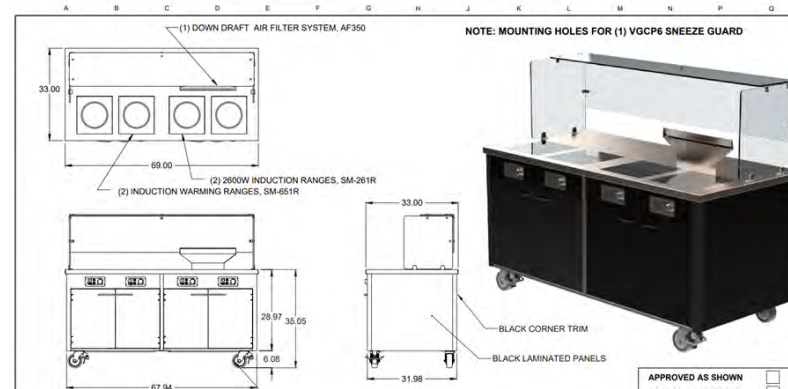
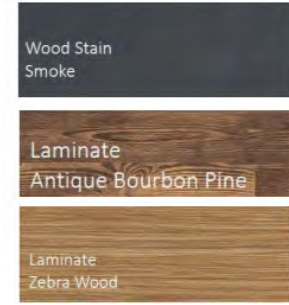

## OUR SERVICES

### **Exceptional Quality, Guaranteed.**

Our products are constructed of high-quality materials, tested and proven to withstand the rigors of commercial use while retaining original luster & performance.

- 1 Premium grade stainless steel
- 2 USA-sourced millwork
- 3 Commercial-grade stone, resin, and fabricated stone





# EQUIPMENT

# EQUIPMENT

**A leading manufacturer of foodservice equipment dedicated to innovation, quality, and design for more than 30 years.**

We are more than just equipment. We go beyond to offer highly customizable solutions and exclusive surfaces capable of integrating with any style or environment.



INDUCTION



TABLETOP



BOH EQUIPMENT

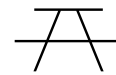

FURNITURE



CUSTOM

# EQUIPMENT

## Induction Solutions

### MAX INDUCTION



### BOH EQUIPMENT



### COOKING STATIONS



# EQUIPMENT

## Induction Solutions

### DROP-IN MAX INDUCTION

MAX Induction that can be flush-mounted for a seamless display or dropped-in to any countertop.



## EQUIPMENT

### Induction Solutions

#### MAX INDUCTION GRIDDLE

Harness the power and precision of induction to effortlessly cook griddle favorites using the MAX Induction Reconfigurable Double Induction Range and stainless steel Griddle Overlay attachment.



## EQUIPMENT

### Induction Solutions

#### BUILT-IN COOKING STATIONS

Provides high-speed heating with quiet, efficient air filtering that removes grease laden vapor and odors all within a stainless steel housing that is ready for easy installation in a display cooking or cabinet base.



## EQUIPMENT

### Induction Solutions

#### FIRE SUPPRESSION MCS

- Equipped with two 3500W MAX Induction Wok Ranges
- Integrated UL300 Fire Suppression System
- Four Stage Filtration System & LCD Menu
- Listed in Compliance with ANSI/UL710B Standard
- Listed in Compliance with ANSI/NSF2 Standard
- 304 Grade Stainless Steel w/ Brushed Finish, Fully Sealed Welds



# EQUIPMENT

## Functional Furniture

CUSTOM TABLES



FROST TOPS



FOOD PROTECTION



## EQUIPMENT

### Versa-Gard Food Protection

- Broad, patented portfolio of **precision-machined** parts
- NSF/ANSI 2 Listed
- Individualized solutions to customer-specific application and needs
- All types of service – operator-served, self-service, convertible and vertical shields
- Full Customization and end-to-end project support

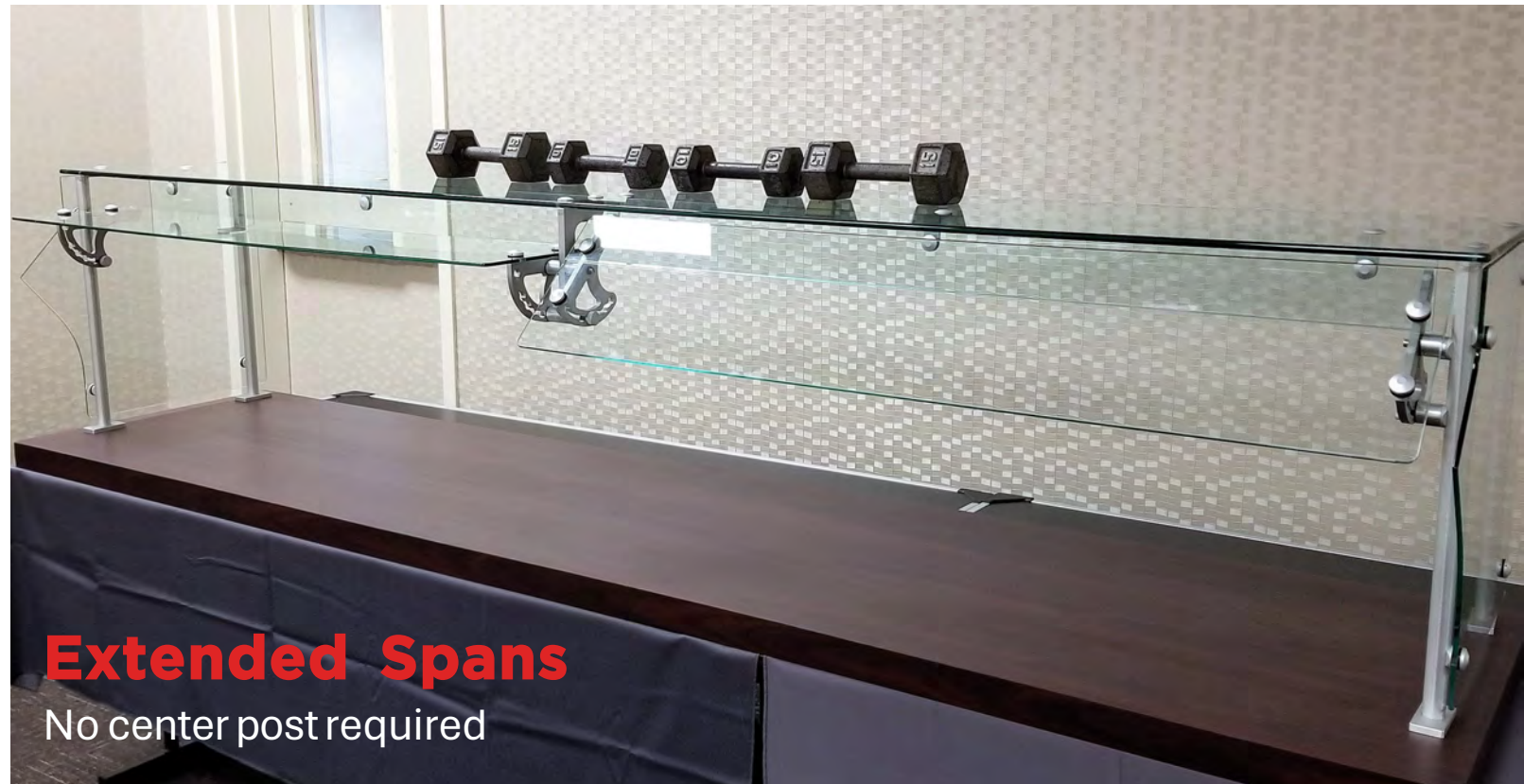

# EQUIPMENT

## Functional Furniture

### SMARTSTONE™ SURFACES & TABLES



TRIVETLESS INDUCTION



FROST-TOP COMPATIBLE



SUPERIOR DURABILITY



PREMIUM FINISHES



NSF-CERTIFIED

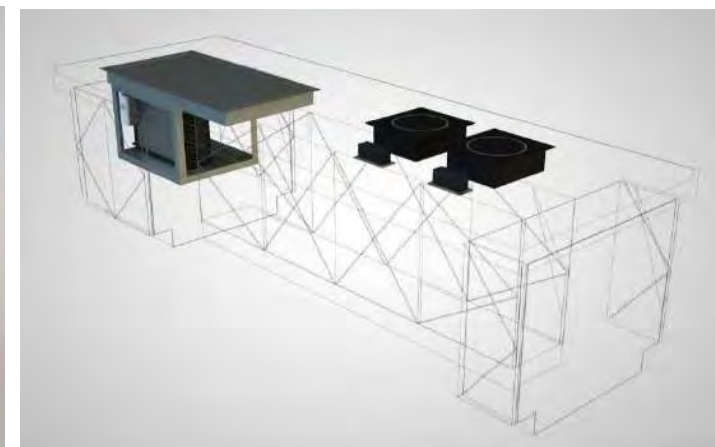



**CUSTOM BUILDS**

## CUSTOM BUILDS

### FOH INDUCTION

#### FK KITCHEN

Worked with end-user and kitchen contractor to redesign their space and elevate the guest dining experience, while also creating a corporate standard that solved for food waste, efficiencies, and space challenges.

What we provided:

- End-user testing & feedback process
- Drop-in induction with low energy/ power consumption + consistent performance
- Efficient use of limited serving space
- On-time production & delivery

**FRESH**  
KITCHEN



## CUSTOM BUILDS

### BOH INDUCTION

#### — BLOOMIN' BRANDS

Liaised with dealer and end-user to develop a custom solution to outfit their BOH kitchens with induction instead of gas.

What we provided:

- Space utilization solutions
- Custom power configurations
- Increased efficiencies for BOH – energy-saving, sustainable products
- Consistent performance & proven reliability
- Competitive pricing and overall cost savings over time



## CUSTOM BUILDS

### CUSTOM FURNITURE

#### — HOMEWOOD SUITES

Our team worked closely with Hilton brand team and interior designer to come up with a dining solution that matched their existing corporate specifications as well as provided a modern and functional aesthetic.

What we provided:

- Hidden induction Communal tables
- NSF-certified SmartStone
- Hidden frost tops
- Custom power requirements
- Technical advisement & development
- On-time production & delivery



## CUSTOM BUILDS

### Food Protection

#### LANCASTER GENERAL HOSPITAL

Worked with consultant and end user to develop a completely custom solution for food protection & sanitation standards.

What we provided:

- Custom sneeze guard solution
- Elevated, all-glass aesthetic
- Accent designs
- Downdraft air filtration
- On-time production & delivery



Penn Medicine  
Lancaster General Health

Spring<sup>TM</sup>  
USA

THANK  
**YOU.**

---

**Visit us on KCL.**

<https://web.kclcad.com/app/M182#models>

**Follow us.**



**Spring**<sup>USA</sup>  
THE EVOLUTION OF INTELLIGENT DESIGN